



Pilot Helicopter (Landing) Operations (Primary Helicopter - EC135)

Region:

Hay Point Gladstone

Name of ship

Agent

- 1. Do you understand that all helicopter communications will be on VHF Channel 10?
Yes No
- 2. Do you understand that any helicopter transfer during the hours of darkness will require your ship to switch on all deck and accommodation lighting?
Yes No
- 3a. Does your ship have a minimum clear area of 22m diameter for the helicopter landing, and a clear approach/ departure flight path of 22m or more across the ship? (see diagram 3(a) below)
Yes No

or

- 3b. If your ship has offset cranes - does it have 13m clear space between the crane and landing hatch side? (see diagram 3(b) below)
Yes No

3(a) Centreline cranes

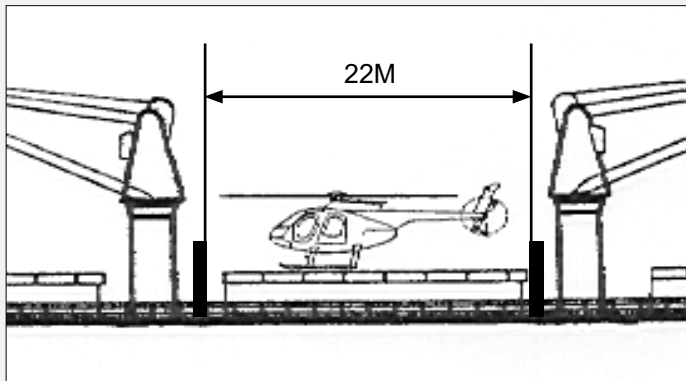

3(b) Shiplside cranes

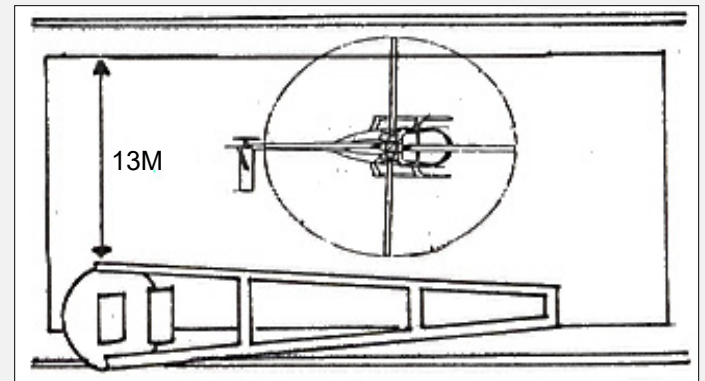

- 4. Is the landing hatch clear for helicopter operations without raising any cranes or derricks?
Yes No
- 5. Will the landing hatch and adjacent hatches be closed and washed clean?
Yes No
- 6. Do you understand there is to be no loose equipment or ship's crew standing on or surrounding the landing hatch?
Yes No
- 7. Will a fire party with charged hoses, foam equipment, proximity suits and rescue equipment be on station clear and upwind of the landing hatch? (equipment as per SOLAS Ch 11.2 Reg 18)
Yes No
- 8. Will a rescue boat be ready for immediate lowering?
Yes No
- 9. Will there be a safe means of access from the landing hatch to the deck?
Yes No
- 10. Do you and your crew understand that crew members are not to approach the helicopter, unless in an emergency?
Yes No

11. Can your ship's landing hatch accept a helicopter of 489kgs per square metre (dynamic load) and or maximum weight 2910kgs (static load)?
Yes No The vessel is not helicopter suitable.
12. Do you have documents to confirm your ship's landing hatch can accept a helicopter of 489kgs per square metre (dynamic load) and or maximum weight 2910kgs (static load), as per Marine Order 57?
Yes No The vessel is not helicopter suitable.
13. Is the landing hatch flat?
Yes No
14. Are the obstructions higher than 30cm on the landing hatch?
Yes No
15. Will your ship comply with the *International Chamber of Shipping Guide to Helicopter-Ship Operations*, as per Marine Order 57?
Yes No

Master's signature

Master's printed name

Date

Ship's stamp

Privacy Statement: The Department of Transport and Main Roads is collecting the information on this form under the provisions of the *Transport Operations (Marine Safety) Act 1994*. The department may disclose this information to authorised departmental officers and officers of Queensland port authorities. Your personal information will not be disclosed to a third party without your consent unless required or authorised to do so by law.